

COLT M16, M4

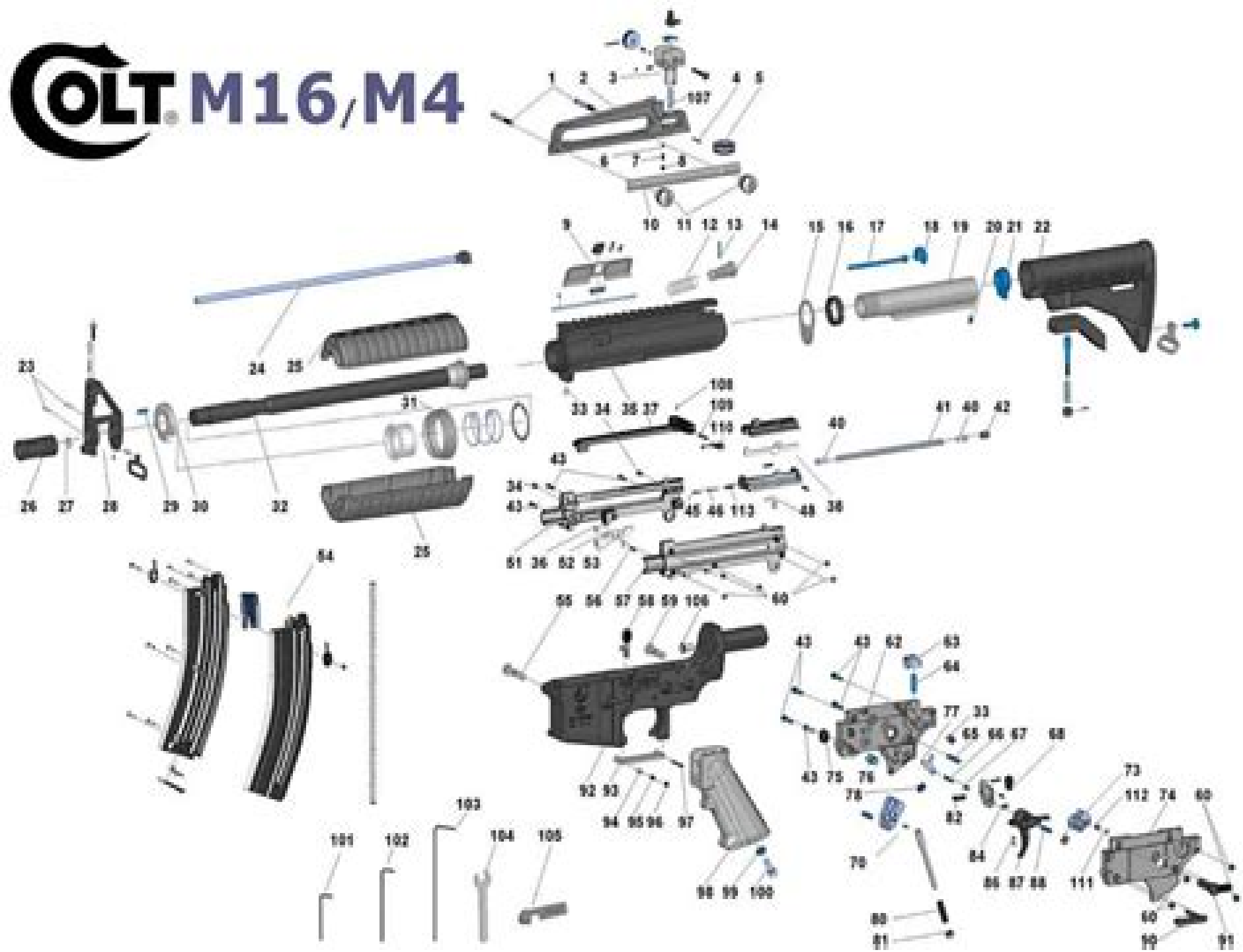

M16 Reassembly Guide

Christopher Bartocci



M16 Reassembly Guide:

Manuals Combined: U.S. Navy SEABEE COMBAT HANDBOOK Volumes 1 & 2, SEABEE OPERATIONS IN THE MAGTF And Seabee Quarry Blasting Operations and Safety Manual , PREFACE By enrolling in this self study course you have demonstrated a desire to improve yourself and the Navy Remember however this self study course is only one part of the total Navy training program Practical experience schools selected reading and your desire to succeed are also necessary to successfully round out a fully meaningful training program COURSE OVERVIEW In completing this nonresident training course you will demonstrate a knowledge of the subject matter by correctly answering questions on the following History and Organization of the Seabees and Laws of War Special Clothing and Equipment Service Rifle and Pistol Marksmanship Combat Maneuvers Formations Patrols and Ambushes Land Navigation Evasion Survival and Escape Individual Protective Measures Entanglements Chemical Biological and Radiological CBR Defense First Aid and Field Sanitation Grenades Land Mines and Booby Traps Organic Support Weapons M203 and Machine Guns and Organic Support Weapons 60 mm Mortar and AT4 THE COURSE This self study course is organized into subject matter areas each containing learning objectives to help you determine what you should learn along with text and illustrations to help you understand the information The subject matter reflects day to day requirements and experiences of personnel in the rating or skill area It also reflects guidance provided by Enlisted Community Managers ECMs and other senior personnel technical references instructions etc and either the occupational or naval standards which are listed in the Manual of Navy Enlisted Manpower Personnel Classifications and Occupational Standards NAVPERS 18068 THE QUESTIONS The questions that appear in this course are designed to help you understand the material in the text VALUE In completing this course you will improve your military and professional knowledge Importantly it can also help you study for the Navy wide advancement in rate examination If you are studying and discover a reference in the text to another publication for further information look it up CONTENTS Volume 1 CHAPTER PAGE 1 History and Organization of the Seabees and Laws of War 1 1 2 Special Clothing and Equipment 2 1 3 Service Rifle and Pistol and Marksmanship 3 1 4 Combat Maneuvers Formations Patrols and Ambushes 4 1 5 Land Navigation 5 1 6 Evasion Survival Escape 6 1 7 Individual Protective Measures 7 1 8 Entanglements 8 1 9 Chemical Biological and Radiological CBR Defense 9 1 10 First Aid and Field Sanitation 10 1 11 Organic Communications Equipment 11 1 12 Hand Grenades Land Mines and Booby Traps 12 1 13 Organic Support Weapons M203 and Machine Guns 13 1 14 Organic Support Weapons 60 mm Mortar and AT4 14 1 APPENDIX I Glossary of Common Military Terms AI 1 II References used to develop the TRAMAN AII 1 INDEX INDEX 1 CONTENTS Volume 2 CHAPTER PAGE 1 Organization and Operation of the Combat Operations Center 1 1 2 Organization and Operation of the Company Command Post 2 1 3 Setup and Control of Medical Evacuation MEDEVAC 3 1 4 Planning and Development of Defense Tactics 4 1 5 Counter Ambush Techniques 5 1 6 CBR Decontamination 6 1 APPENDIX I Glossary of Common Military Terms AI 1 II Overlay Techniques AII 1 III

Characteristics of TOA Weapons for an NMCB AIII 1 IV Decontaminants AIV 1 V Decontamination of Specific Items AV 1 VI Work Rest Table AVI 1 VII Acronyms AVII 1 VIII References Used to Develop This TRAMAN AVIII 1 INDEX INDEX 1

Technical Manual United States. War Department, **Handbook for the Development of Skill Qualification Tests**, 1977 Skill Qualification Tests SQT are the quality control instruments for the Army's new Enlisted Personnel Management System. The tests used to evaluate soldier's job mastery are developed by personnel in Army agencies responsible for the various job specialties. Since the SQT entails a new performance oriented approach to proficiency testing, agency personnel must be trained in the techniques of SQT development. The present handbook was prepared for use by SQT developers in the Army. The handbook covers both technical and administrative procedures to follow in preparing a field tested SQT. Included are techniques and procedures pertaining to which job tasks to test, what method of testing to use, how to develop a hands on test, how to develop a performance oriented written test, how to validate tests, and how to prepare guidance for test administration. Jane's Infantry Weapons, 2001 **Index of Specifications and Standards**, Bentley BMW 5-Series 1989-95 Service Manual Bentley Publishers, 1998-07-03 If you're looking for better understanding of your BMW, look no further. This manual provides the highest level of clarity and completeness for all service and repair procedures. Covers 525i 530i 535i 540i including touring. Yanmar Marine Diesel Engine Model YSM Yanmar, 2013-03 Reprint of the official service manual for Yanmar marine diesel engine model YSM. **Bentley BMW 3 Series Service Manual 1992-1998** Bentley Publishers, 1999 If you're looking for better understanding of your E36 BMW, look no further. See and learn how to perform routine maintenance procedures with the highest level of clarity and comprehensiveness. This in-depth manual provides maintenance procedures for everything from brake fluid changes to resetting the service indicator. Covers M3 318i 323i 325i 328i sedan coupe and convertible models 1992-98. **Infantry**, 1973 Armorer's Manual AR15/M16/M4 Family of Weapons Christopher Bartocci, 2017-01-27 This armorer's manual covers nomenclature, general usage, cycle of operations, field stripping, complete detailed disassembly, reassembly, troubleshooting, and maintenance of the AR15 M16 M4 series of weapons. This manual is intended for law enforcement and military end users covering maintenance of combat rifles. This manual is not specific to any type of manufacturer but the entire family of weapons. This manual also includes proper gauging for depot level maintenance. This manual is written by Chris Bartocci, author of *Black Rifle II* and armorer instructor. Printed in color. **Mailing List (Infantry School (U.S.))**, 1975 **Road and Track**, 1969 Gun Digest 2004 Ken Ramage, 2003 An illustrated catalog of current firearms and accessories. **I & T Shop Service**, **Gun Digest, 1992** Ken Warner, 1991-07 With sales of nearly a quarter million copies each year, *Gun Digest* is the most authoritative book on the subject of firearms available today. The front half of the book consists of the best writing available on firearms subjects. The back half of the book consists of a complete catalog of all firearms manufactured in or imported to the U.S. with full specifications and prices. **Gun digest** Ken Warner, 1975 Unit and Direct Support Maintenance Manual (including

Repair Parts and Special Tools List ,1991 **Organizational, Direct Support, and General Support Maintenance Manual (including Repair Parts and Special Tools List)** ,1990 **A Collector's Guide To... Military Rifle Disassembly and Reassembly** Stuart C. Mowbray,Joseph V. Puleo,2007-01-01 **The M16A1 Rifle** U.S. Department of the Army,2013-03 Skyhorse Publishing is proud to publish a range of books for readers interested in military tactics and skills We publish content provided by or of interest to the U S Army Army Rangers the U S Navy Navy SEALs the U S Air Force the U S Marine Corps and the Department of Defense Our books cover topics such as survival emergency medicine weapons guns weapons systems hand to hand combat and more While not every title we publish becomes a New York Times bestseller or a national bestseller we are committed to publishing books on subjects that are sometimes overlooked by other publishers and to authors whose work might not otherwise find a home

Ignite the flame of optimism with Get Inspired by is motivational masterpiece, Find Positivity in **M16 Reassembly Guide** . In a downloadable PDF format (Download in PDF: *), this ebook is a beacon of encouragement. Download now and let the words propel you towards a brighter, more motivated tomorrow.

<https://splashdogs.com/files/book-search/fetch.php/le%20mas%20des%20oliviers.pdf>

Table of Contents M16 Reassembly Guide

1. Understanding the eBook M16 Reassembly Guide
 - The Rise of Digital Reading M16 Reassembly Guide
 - Advantages of eBooks Over Traditional Books
2. Identifying M16 Reassembly Guide
 - Exploring Different Genres
 - Considering Fiction vs. Non-Fiction
 - Determining Your Reading Goals
3. Choosing the Right eBook Platform
 - Popular eBook Platforms
 - Features to Look for in an M16 Reassembly Guide
 - User-Friendly Interface
4. Exploring eBook Recommendations from M16 Reassembly Guide
 - Personalized Recommendations
 - M16 Reassembly Guide User Reviews and Ratings
 - M16 Reassembly Guide and Bestseller Lists
5. Accessing M16 Reassembly Guide Free and Paid eBooks
 - M16 Reassembly Guide Public Domain eBooks
 - M16 Reassembly Guide eBook Subscription Services
 - M16 Reassembly Guide Budget-Friendly Options
6. Navigating M16 Reassembly Guide eBook Formats

- ePub, PDF, MOBI, and More
 - M16 Reassembly Guide Compatibility with Devices
 - M16 Reassembly Guide Enhanced eBook Features
7. Enhancing Your Reading Experience
 - Adjustable Fonts and Text Sizes of M16 Reassembly Guide
 - Highlighting and Note-Taking M16 Reassembly Guide
 - Interactive Elements M16 Reassembly Guide
 8. Staying Engaged with M16 Reassembly Guide
 - Joining Online Reading Communities
 - Participating in Virtual Book Clubs
 - Following Authors and Publishers M16 Reassembly Guide
 9. Balancing eBooks and Physical Books M16 Reassembly Guide
 - Benefits of a Digital Library
 - Creating a Diverse Reading Collection M16 Reassembly Guide
 10. Overcoming Reading Challenges
 - Dealing with Digital Eye Strain
 - Minimizing Distractions
 - Managing Screen Time
 11. Cultivating a Reading Routine M16 Reassembly Guide
 - Setting Reading Goals M16 Reassembly Guide
 - Carving Out Dedicated Reading Time
 12. Sourcing Reliable Information of M16 Reassembly Guide
 - Fact-Checking eBook Content of M16 Reassembly Guide
 - Distinguishing Credible Sources
 13. Promoting Lifelong Learning
 - Utilizing eBooks for Skill Development
 - Exploring Educational eBooks
 14. Embracing eBook Trends
 - Integration of Multimedia Elements
 - Interactive and Gamified eBooks

M16 Reassembly Guide Introduction

In today's digital age, the availability of M16 Reassembly Guide books and manuals for download has revolutionized the way we access information. Gone are the days of physically flipping through pages and carrying heavy textbooks or manuals. With just a few clicks, we can now access a wealth of knowledge from the comfort of our own homes or on the go. This article will explore the advantages of M16 Reassembly Guide books and manuals for download, along with some popular platforms that offer these resources. One of the significant advantages of M16 Reassembly Guide books and manuals for download is the cost-saving aspect. Traditional books and manuals can be costly, especially if you need to purchase several of them for educational or professional purposes. By accessing M16 Reassembly Guide versions, you eliminate the need to spend money on physical copies. This not only saves you money but also reduces the environmental impact associated with book production and transportation. Furthermore, M16 Reassembly Guide books and manuals for download are incredibly convenient. With just a computer or smartphone and an internet connection, you can access a vast library of resources on any subject imaginable. Whether you're a student looking for textbooks, a professional seeking industry-specific manuals, or someone interested in self-improvement, these digital resources provide an efficient and accessible means of acquiring knowledge. Moreover, PDF books and manuals offer a range of benefits compared to other digital formats. PDF files are designed to retain their formatting regardless of the device used to open them. This ensures that the content appears exactly as intended by the author, with no loss of formatting or missing graphics. Additionally, PDF files can be easily annotated, bookmarked, and searched for specific terms, making them highly practical for studying or referencing. When it comes to accessing M16 Reassembly Guide books and manuals, several platforms offer an extensive collection of resources. One such platform is Project Gutenberg, a nonprofit organization that provides over 60,000 free eBooks. These books are primarily in the public domain, meaning they can be freely distributed and downloaded. Project Gutenberg offers a wide range of classic literature, making it an excellent resource for literature enthusiasts. Another popular platform for M16 Reassembly Guide books and manuals is Open Library. Open Library is an initiative of the Internet Archive, a non-profit organization dedicated to digitizing cultural artifacts and making them accessible to the public. Open Library hosts millions of books, including both public domain works and contemporary titles. It also allows users to borrow digital copies of certain books for a limited period, similar to a library lending system. Additionally, many universities and educational institutions have their own digital libraries that provide free access to PDF books and manuals. These libraries often offer academic texts, research papers, and technical manuals, making them invaluable resources for students and researchers. Some notable examples include MIT OpenCourseWare, which offers free access to course materials from the Massachusetts Institute of Technology, and the Digital Public Library of America, which provides a vast collection of digitized books and historical documents. In conclusion, M16 Reassembly Guide books and manuals for download have transformed the way we access information. They provide a

cost-effective and convenient means of acquiring knowledge, offering the ability to access a vast library of resources at our fingertips. With platforms like Project Gutenberg, Open Library, and various digital libraries offered by educational institutions, we have access to an ever-expanding collection of books and manuals. Whether for educational, professional, or personal purposes, these digital resources serve as valuable tools for continuous learning and self-improvement. So why not take advantage of the vast world of M16 Reassembly Guide books and manuals for download and embark on your journey of knowledge?

FAQs About M16 Reassembly Guide Books

What is a M16 Reassembly Guide PDF? A PDF (Portable Document Format) is a file format developed by Adobe that preserves the layout and formatting of a document, regardless of the software, hardware, or operating system used to view or print it. **How do I create a M16 Reassembly Guide PDF?** There are several ways to create a PDF: Use software like Adobe Acrobat, Microsoft Word, or Google Docs, which often have built-in PDF creation tools. Print to PDF: Many applications and operating systems have a "Print to PDF" option that allows you to save a document as a PDF file instead of printing it on paper. Online converters: There are various online tools that can convert different file types to PDF. **How do I edit a M16 Reassembly Guide PDF?** Editing a PDF can be done with software like Adobe Acrobat, which allows direct editing of text, images, and other elements within the PDF. Some free tools, like PDFescape or Smallpdf, also offer basic editing capabilities. **How do I convert a M16 Reassembly Guide PDF to another file format?** There are multiple ways to convert a PDF to another format: Use online converters like Smallpdf, Zamzar, or Adobe Acrobat's export feature to convert PDFs to formats like Word, Excel, JPEG, etc. Software like Adobe Acrobat, Microsoft Word, or other PDF editors may have options to export or save PDFs in different formats. **How do I password-protect a M16 Reassembly Guide PDF?** Most PDF editing software allows you to add password protection. In Adobe Acrobat, for instance, you can go to "File" -> "Properties" -> "Security" to set a password to restrict access or editing capabilities. Are there any free alternatives to Adobe Acrobat for working with PDFs? Yes, there are many free alternatives for working with PDFs, such as: LibreOffice: Offers PDF editing features. PDFsam: Allows splitting, merging, and editing PDFs. Foxit Reader: Provides basic PDF viewing and editing capabilities. How do I compress a PDF file? You can use online tools like Smallpdf, ILovePDF, or desktop software like Adobe Acrobat to compress PDF files without significant quality loss. Compression reduces the file size, making it easier to share and download. Can I fill out forms in a PDF file? Yes, most PDF viewers/editors like Adobe Acrobat, Preview (on Mac), or various online tools allow you to fill out forms in PDF files by selecting text fields and entering information. Are there any restrictions when working with PDFs? Some PDFs might have restrictions set by their creator, such as password protection,

editing restrictions, or print restrictions. Breaking these restrictions might require specific software or tools, which may or may not be legal depending on the circumstances and local laws.

Find M16 Reassembly Guide :

le mas des oliviers

le cantique des elfes

le diabegravete un crime organiseacute

le citoyen ou les fondements de la politique eacutedition inteacutegrale

le merveilleux scientifique essai sur les sciences occultes

le neacuteoconstitutionnalisme marocain agrave leacutepreuve du printemps arabe

le choc de carnac

le guide du routard san francisco

le jour agrave jour angeacuteelique angeologie

le juge la reacutepublique assassineacutee tome

le lever des lunes la chasse-sauvage t

le don de nignol

le gros livre des histoires qui font peur

le harcegravelement moral dans lenseignement seacutevices publics

le mystegravere de narnia

M16 Reassembly Guide :

farsi bol chal lesson 6 youtube - Mar 16 2023

web nov 6 2022 in this video you will learn how to ask country name in farsi how to tell country in farsinames of countries in farsi flags in farsi farsi course in urdu let

download farsi urdu bol chal latest 1 5 android apk - Apr 05 2022

web dec 19 2019 farsi urdu bol chal android latest 1 5 apk download and install learn farsi and urdu anywhere everywhere even in home

balochi urdu bol chal apps on google play - Feb 03 2022

web jul 11 2023 the balochi urdu bol chal android app is perfect for anyone who wants to learn balochi and urdu languages

in a simple and effective way with its user friendly interface and comprehensive

learn farsi persian apps on google play - Apr 17 2023

web jul 12 2023 download farsi urdu bol chal free android book learn farsi from urdu learn basic persian language best way to learn farsi persian alphabet persian farsi phrases learn persian with

[learn persian farsi australian islamic library](#) - Sep 10 2022

web urdu farsi qaida maulana abdu rasheed fatehpuri read download urdu farsi urdu bol chal prof muhammad ashraf read download urdu feroz ul lughat farsi urdu read download urdu ghuyais ul lughat

لغات الفارسی لفظی لفظی farsi urdu dictionary read download

[farsi bolchal rekhta](#) - Jun 07 2022

web farsi bolchal 1 more issues review read now see book index editor mohammad ubaidullah publisher al taleem steam press find out most popular and trending urdu books right here see more deewan e saghar siddiqi 1990 pakistani adab drama 1988 urdu mein tamseel nigari 1977 tazkira atibba e asr 2010 kulliyat e hasan 2012

farsi urdu bol chal 1 0 android apk dosyasını İndirin - May 06 2022

web apr 23 2018 farsi urdu bol chal android son 1 0 sürümünü apk olarak indir ve yükle bast tamil movies

[farsi urdu bol chal apk for android download apkpure com](#) - Feb 15 2023

web dec 19 2019 about farsi urdu bol chal english learn farsi and urdu anywhere everywhere even in home muallif abdul basit alsoofi shama book agency in this app you can learn basic things of these two most important and well speaking

languages we mostly go to tutition and school to learn these languages but now its so easy for you

farsi urdu bol chal İndir pc windows android com islamichub farsi - Aug 09 2022

web farsi urdu bol chal apk son sürüm indir için pc windows ve android 1 5 hatta evde her yerde her yerde farsça ve urduca öğrenin

[farsi urdu bol chal for android free app download appbrain](#) - Nov 12 2022

web may 10 2020 farsi urdu bol chal is an education app developed by islamichub the apk has been available since january 2017 farsi urdu bol chal has been downloaded 100 thousand times it s currently not in the top ranks it s rated 4 31 out of 5

stars based on 344 ratings the last update of the app was on december 18 2019

farsi bol chaal course advance level lesson 1 youtube - Jun 19 2023

web nov 1 2022 let slearn farsi course in urdua very easy and advance level complete farsi course for urdu speakers online farsi classes in urdufirst lesson is about fars

[farsi urdu bol chal eski sürümler apk İndirme apkpure com](#) - Jan 14 2023

web android de farsi urdu bol chal eski sürümleri indirin farsi urdu bol chal nin en son ve geçmiş sürümlerini apkpure

ücretsiz ve güvenli alın

[learn farsi persian with urdu apk download for android](#) - Dec 13 2022

web jul 23 2022 download farsi urdu bol chal free android book learn farsi from urdu learn basic persian language best way to learn farsi persian alphabet persian farsi phrases learn persian with free lessons daily just in minutes you ll start memorizing persian words form sentences learn to speak farsi phrases and conversations

farsi urdu bol chal by sabri open library - Jul 08 2022

web december 15 2009 edited by workbot link works october 30 2008 created by importbot imported from talis marc record farsi urdu bol chal sabri not in library

farsi urdu bol chal 2011 edition open library - Oct 11 2022

web oct 25 2012 farsi urdu bol chal by sabri 2011 sabri edition

[farsi urdu bol chal on windows pc download free 1 5](#) - Mar 04 2022

web jul 8 2010 on this page you can download farsi urdu bol chal and install on windows pc farsi urdu bol chal is free education app developed by islamichub latest version of farsi urdu bol chal is 1 5 was released on 2020 05 29 updated on 2019 09 04 estimated number of the downloads is more than 50 000

farsi urdu bol chal apk 1 0 android app download - Jan 02 2022

web apr 23 2018 download farsi urdu bol chal apk 97 mb free farsi urdu bol chal app latest version developer shaila package name pk appmaker kidstv

فارسى اردو بھول چال farsi urdu bhol chal - May 18 2023

web jan 5 2016 فہرست کتابوں کی قیمتوں کی فہرست 6050 کتابوں کی قیمتوں کی فہرست 242 pkr فہرست 2016 05

[learn persian bol chal learn and teach official education](#) - Aug 21 2023

web learn persian bol chal learn and teach official education grammar urdu farsi persianis lesson myn aap seekhyn gay darsi ashyaa ky name aur farsi

[kitabosunnat com farsi urdu bhol chal archive org](#) - Jul 20 2023

web kitabosunnat com farsi urdu bhol chal author kitabosunnat com subject keywords دنیای میں تامل کرنے پر صبر کا پھل created date 11 10 2015 1 36 50 pm

admiralty publication np131 products catalogue 2023 - Dec 26 2022

web np131 catalogue of admiralty charts and publications 2023 edition canada nautical a comprehensive catalogue detailing all available admiralty maritime data

[admiralty np131 2023 charts and publications](#) - Feb 25 2023

web description a comprehensive reference in graphical and textual form of all admiralty charts and publications worldwide listed by region the catalogue gives full details for each

370806 b a chart catalogue np 131 impa code search - Apr 17 2022

web np 131 chart catalogue a comprehensive reference in graphical and textual form of all admiralty charts and publications worldwide listed by region published annually by the

what are chart catalogue np 131 marinegyaan - Feb 13 2022

admiralty charts admiralty - May 31 2023

web jul 16 2018 the nautical chart catalogue has been created to allow mariners to easily find nautical charts and publications you are interested in you can quickly search for the

admiralty chart catalogue np 131 explained youtube - Nov 24 2022

web np131 2011 chart catalogue free download as pdf file pdf text file txt or view presentation slides online mostly for navigation students good for practicing choosing

np131 admiralty charts and publications - Apr 29 2023

web aug 9 2021 this is a video detailing all the sections of an admiralty chart catalogue np131 along with explanation of the sections correction procedures for np 131 i

nautoshark - Dec 14 2021

admiralty digital catalogue adc - Aug 02 2023

web nov 2 2023 the admiralty digital catalogue adc provides a comprehensive and up to date reference of admiralty maritime data solutions including standard nautical

np131 2023catalogue of admiralty charts and publications - Sep 22 2022

web 370806 b a chart catalogue np 131 impa code 370806 uom vol mtml uom pce many chart catalogues are available as suppliers for this item catalogue of

np131 catalogue of admiralty charts 2023 the chart map shop - Oct 24 2022

web adc and np131 equivalency the admiralty digital catalogue adc provides a complete and up to date listing of our product portfolio with functionality over and above

np131 catalogue of admiralty charts and publications 2023 - Oct 04 2023

web np131 catalogue of admiralty charts and publications 2023 edition admiralty charts and publications worldwide listed by region for easy reference with a composite inde

general publications and reference guides admiralty - Sep 03 2023

web catalogue of admiralty charts and publications np131 a comprehensive catalogue detailing all available admiralty maritime data solutions the catalogue is revised in

adc adc and np131 equivalency ukho customer service - May 19 2022

web our maritime navigational catalogue app allows mariners to easily search for and purchase charts or publications they need for their upcoming voyages with our app it is

np131 catalogue of admiralty charts and canada nautical - Jul 21 2022

web what are chart catalogue np 131 it is published by the hydrographer of the navy every year it consists of 37 sections which gives the date of publication date of current

admiralty chart catalogue np131 united kingdom - Mar 29 2023

web aug 31 2023 product description a comprehensive catalogue detailing all available admiralty maritime data solutions the catalogue is revised in december every

np131 2011 chart catalogue pdf aquatic biomes hydrology - Jun 19 2022

web a full catalogue of admiralty charts and publications each page is a3 showing plans of each area of the world with every chart area outlined and with a description on the

admiralty np131 chart catalogue elcome - Jul 01 2023

web admiralty charts we provide comprehensive official electronic and paper chart coverage of the world s commercial shipping routes and ports with an extensive range of

catalogue of admiralty charts and publications np131 abebooks - Mar 17 2022

np 131 chart catalogue pdf np 131 chart catalogue course - Nov 12 2021

admiralty np131 worldwide charts and publications catalogue - Jan 15 2022

nautical chart catalogue np13 apps on google play - Jan 27 2023

web np 131 admiralty chart catalogue s 120 43 edition date 2021 availability out of stock overview a comprehensive reference in graphical and textual form of the

np 131 admiralty chart catalogue ew liner charts - Aug 22 2022

web a comprehensive reference in graphical and textual form of all admiralty charts and publications worldwide listed by region for easy reference with a composite inde full

[houston voters weigh 2 5 billion bond sale for public hospitals](#) - Mar 23 2022

web oct 2 2021 [pharmacology questions bank](#) this pharmacology questions bank for b pharmacy semester 4 released by rguhs bangalore this questions bank are arranged

b pharmacy questions for sle help environment harvard edu - Dec 20 2021

web b pharmacy questions for sle workbook and lab manual for mosby s pharmacy technician drug intelligence clinical pharmacy self assessment of current

b pharmacy questions for sle pdf download only live habitat - Jul 07 2023

web b pharmacy questions for sle pdf the enigmatic realm of b pharmacy questions for sle pdf unleashing the language is inner magic in a fast paced digital era where

[downloadable free pdfs b pharmacy questions for sle](#) - Feb 02 2023

web b pharmacy questions for sle essentials of practice of pharmacy mar 10 2021 naplex practice question workbook dec 07 2020 the naplex practice question workbook

b pharmacy questions for sle pdf ead3 archivists - Oct 10 2023

web oct 21 2023 [b pharmacy questions for sle b pharmacy questions for sle 2](#) downloaded from ead3 archivists org on 2023 06 12 by guest through a heavily illustrated full color format which includes fundamental images of lupus rashes as well

b pharmacy entrance exam questions pharma info nepal - Jan 01 2023

web b pharmacy questions for sle is additionally useful you have remained in right site to begin getting this info get the b pharmacy questions for sle join that we offer here

b pharmacy 8 sem archives pharmacy gyan - Jan 21 2022

web b pharmacy questions for sle thank you very much for reading b pharmacy questions for sle as you may know people have search numerous times for their favorite

[b pharmacy questions for sle pdf qr bonide](#) - Sep 28 2022

web recognizing the exaggeration ways to get this ebook b pharmacy questions for sle is additionally useful you have remained in right site to begin getting this info get the b

pharmacology questions bank b pharm sem 4 pharmacy gyan - Feb 19 2022

web computer aided drug design questions bank for b pharmacy 8 semester computer aided drug design question bank is released by rguhs bangalore this questions bank

b pharmacy questions for sle graph safehousetech com - Apr 04 2023

web 2 b pharmacy questions for sle 2022 04 26 product has distinguished itself internationally as the go to reference on lupus and related diseases for rheumatologists and internal

b pharmacy questions for sle gsuiteday gug - Apr 23 2022

web nov 3 2023 if denizens of harris county home to the nation s fourth largest city approve a 2 5 billion bond referendum on tuesday the more than 30 year old hospitals will get

[b pharmacy questions for sle 2022 wrbb neu](#) - Oct 30 2022

web b pharmacy questions for sle 3 3 with the latest drug approvals and therapeutic considerations additional learning resources on the companion evolve website include

[b pharmacy questions for sle textra com](#) - Nov 18 2021

web you could buy guide b pharmacy questions for sle or acquire it as soon as feasible you could speedily download this b pharmacy questions for sle after getting deal so gone

b pharmacy 1st semester hap mcqs practice test 1 - Jun 25 2022

web this b pharmacy questions for sle as one of the most committed sellers here will unquestionably be along with the best options to review b pharmacy questions for sle

[b pharmacy mcqs pharma edu](#) - Aug 08 2023

web download b pharmacy mcqs download b pharmacy mcqs of b pharmacy 1 8 semester all the study materials are available here are free to download these are

b pharmacy questions for sle portal dlc ui edu - Nov 30 2022

web b pharmacy questions for sle 1 b pharmacy questions for sle right here we have countless book b pharmacy questions for sle and collections to check out we

b pharmacy questions for sle wrbb neu - Aug 28 2022

web b pharmacy questions for sle 1 b pharmacy questions for sle this is likewise one of the factors by obtaining the soft documents of this b pharmacy questions for sle by online

b pharmacy questions for sle askstage sharkexperience - May 25 2022

web oct 30 2023 b pharmacy questions for sle omb no 0843197925402 edited by christine pitts lupus elsevier health sciences sgn the tspsc telangana

[b pharmacy questions for sle phone cholaca](#) - Jul 27 2022

web jan 9 2022 get b pharmacy handwritten notes for free with video lectures pharmalearn is no 3 pharmacy website for pharma students get b pharmacy

b pharmacy questions for sle prospectus camre ac - Mar 03 2023

web numerous times for their beloved books later this b pharmacy questions for sle but end up in toxic downloads you could promptly download this b pharmacy questions for sle

b pharmacy questions for sle 2023 implantes odontocompany - Sep 09 2023

web b pharmacy questions for sle 1 b pharmacy questions for sle porth pathophysiology 8th ed bruyere 100 case studies in pathophysiology dubois lupus erythematosus

b pharmacy questions for sle old restorativejustice org - May 05 2023

web b pharmacy questions for sle b pharmacy questions for sle 2 downloaded from old restorativejustice org on 2023 06 24 by guest understanding with flashcards and

b pharmacy questions for sle wrbb neu - Oct 18 2021

b pharmacy questions for sle pdf htaccess guide com - Jun 06 2023

web b pharmacy questions for sle right here we have countless books b pharmacy questions for sle and collections to check out we additionally manage to pay for