

**JUKI**

High Speed 1-Needle Cylinder Bed Lockstitch  
Bar Tacking Industrial Sewing Machine

高速一本針本縫筒形閉止めミシン

**LK-1850**

Series

# PARTS LIST

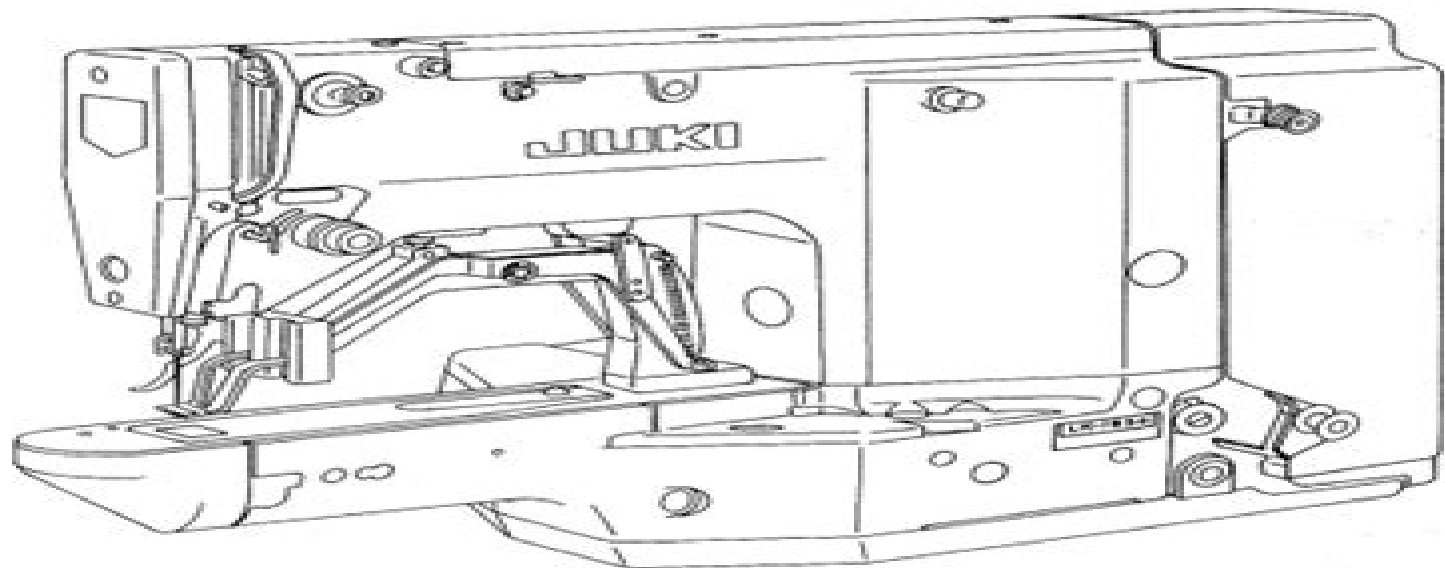

BE185030PJA  
No.0200-09

# Juki Lk 1850 Parts Manual User Guide

**Chilton Book Company**



**Juki Lk 1850 Parts Manual User Guide:**

**Chilton's Labor Guide and Parts Manual** Chilton Book Company, 1974

Recognizing the quirk ways to get this book **Juki Lk 1850 Parts Manual User Guide** is additionally useful. You have remained in right site to begin getting this info. get the Juki Lk 1850 Parts Manual User Guide associate that we give here and check out the link.

You could buy guide Juki Lk 1850 Parts Manual User Guide or get it as soon as feasible. You could speedily download this Juki Lk 1850 Parts Manual User Guide after getting deal. So, like you require the books swiftly, you can straight acquire it. Its consequently utterly easy and hence fats, isnt it? You have to favor to in this look

<https://splashdogs.com/files/uploaded-files/Documents/math%20practice%20test%20for%209th%20grade%20eoct.pdf>

## **Table of Contents Juki Lk 1850 Parts Manual User Guide**

1. Understanding the eBook Juki Lk 1850 Parts Manual User Guide
  - The Rise of Digital Reading Juki Lk 1850 Parts Manual User Guide
  - Advantages of eBooks Over Traditional Books
2. Identifying Juki Lk 1850 Parts Manual User Guide
  - Exploring Different Genres
  - Considering Fiction vs. Non-Fiction
  - Determining Your Reading Goals
3. Choosing the Right eBook Platform
  - Popular eBook Platforms
  - Features to Look for in an Juki Lk 1850 Parts Manual User Guide
  - User-Friendly Interface
4. Exploring eBook Recommendations from Juki Lk 1850 Parts Manual User Guide
  - Personalized Recommendations
  - Juki Lk 1850 Parts Manual User Guide User Reviews and Ratings
  - Juki Lk 1850 Parts Manual User Guide and Bestseller Lists
5. Accessing Juki Lk 1850 Parts Manual User Guide Free and Paid eBooks

- Juki Lk 1850 Parts Manual User Guide Public Domain eBooks
  - Juki Lk 1850 Parts Manual User Guide eBook Subscription Services
  - Juki Lk 1850 Parts Manual User Guide Budget-Friendly Options
6. Navigating Juki Lk 1850 Parts Manual User Guide eBook Formats
    - ePub, PDF, MOBI, and More
    - Juki Lk 1850 Parts Manual User Guide Compatibility with Devices
    - Juki Lk 1850 Parts Manual User Guide Enhanced eBook Features
  7. Enhancing Your Reading Experience
    - Adjustable Fonts and Text Sizes of Juki Lk 1850 Parts Manual User Guide
    - Highlighting and Note-Taking Juki Lk 1850 Parts Manual User Guide
    - Interactive Elements Juki Lk 1850 Parts Manual User Guide
  8. Staying Engaged with Juki Lk 1850 Parts Manual User Guide
    - Joining Online Reading Communities
    - Participating in Virtual Book Clubs
    - Following Authors and Publishers Juki Lk 1850 Parts Manual User Guide
  9. Balancing eBooks and Physical Books Juki Lk 1850 Parts Manual User Guide
    - Benefits of a Digital Library
    - Creating a Diverse Reading Collection Juki Lk 1850 Parts Manual User Guide
  10. Overcoming Reading Challenges
    - Dealing with Digital Eye Strain
    - Minimizing Distractions
    - Managing Screen Time
  11. Cultivating a Reading Routine Juki Lk 1850 Parts Manual User Guide
    - Setting Reading Goals Juki Lk 1850 Parts Manual User Guide
    - Carving Out Dedicated Reading Time
  12. Sourcing Reliable Information of Juki Lk 1850 Parts Manual User Guide
    - Fact-Checking eBook Content of Juki Lk 1850 Parts Manual User Guide
    - Distinguishing Credible Sources
  13. Promoting Lifelong Learning
    - Utilizing eBooks for Skill Development

- Exploring Educational eBooks
14. Embracing eBook Trends
- Integration of Multimedia Elements
  - Interactive and Gamified eBooks

### **Juki Lk 1850 Parts Manual User Guide Introduction**

Free PDF Books and Manuals for Download: Unlocking Knowledge at Your Fingertips In today's fast-paced digital age, obtaining valuable knowledge has become easier than ever. Thanks to the internet, a vast array of books and manuals are now available for free download in PDF format. Whether you are a student, professional, or simply an avid reader, this treasure trove of downloadable resources offers a wealth of information, conveniently accessible anytime, anywhere. The advent of online libraries and platforms dedicated to sharing knowledge has revolutionized the way we consume information. No longer confined to physical libraries or bookstores, readers can now access an extensive collection of digital books and manuals with just a few clicks. These resources, available in PDF, Microsoft Word, and PowerPoint formats, cater to a wide range of interests, including literature, technology, science, history, and much more. One notable platform where you can explore and download free Juki Lk 1850 Parts Manual User Guide PDF books and manuals is the internet's largest free library. Hosted online, this catalog compiles a vast assortment of documents, making it a veritable goldmine of knowledge. With its easy-to-use website interface and customizable PDF generator, this platform offers a user-friendly experience, allowing individuals to effortlessly navigate and access the information they seek. The availability of free PDF books and manuals on this platform demonstrates its commitment to democratizing education and empowering individuals with the tools needed to succeed in their chosen fields. It allows anyone, regardless of their background or financial limitations, to expand their horizons and gain insights from experts in various disciplines. One of the most significant advantages of downloading PDF books and manuals lies in their portability. Unlike physical copies, digital books can be stored and carried on a single device, such as a tablet or smartphone, saving valuable space and weight. This convenience makes it possible for readers to have their entire library at their fingertips, whether they are commuting, traveling, or simply enjoying a lazy afternoon at home. Additionally, digital files are easily searchable, enabling readers to locate specific information within seconds. With a few keystrokes, users can search for keywords, topics, or phrases, making research and finding relevant information a breeze. This efficiency saves time and effort, streamlining the learning process and allowing individuals to focus on extracting the information they need. Furthermore, the availability of free PDF books and manuals fosters a culture of continuous learning. By removing financial barriers, more people can access educational resources and pursue lifelong learning, contributing to personal growth and professional development. This democratization of knowledge promotes

intellectual curiosity and empowers individuals to become lifelong learners, promoting progress and innovation in various fields. It is worth noting that while accessing free Juki Lk 1850 Parts Manual User Guide PDF books and manuals is convenient and cost-effective, it is vital to respect copyright laws and intellectual property rights. Platforms offering free downloads often operate within legal boundaries, ensuring that the materials they provide are either in the public domain or authorized for distribution. By adhering to copyright laws, users can enjoy the benefits of free access to knowledge while supporting the authors and publishers who make these resources available. In conclusion, the availability of Juki Lk 1850 Parts Manual User Guide free PDF books and manuals for download has revolutionized the way we access and consume knowledge. With just a few clicks, individuals can explore a vast collection of resources across different disciplines, all free of charge. This accessibility empowers individuals to become lifelong learners, contributing to personal growth, professional development, and the advancement of society as a whole. So why not unlock a world of knowledge today? Start exploring the vast sea of free PDF books and manuals waiting to be discovered right at your fingertips.

### **FAQs About Juki Lk 1850 Parts Manual User Guide Books**

1. Where can I buy Juki Lk 1850 Parts Manual User Guide books? Bookstores: Physical bookstores like Barnes & Noble, Waterstones, and independent local stores. Online Retailers: Amazon, Book Depository, and various online bookstores offer a wide range of books in physical and digital formats.
2. What are the different book formats available? Hardcover: Sturdy and durable, usually more expensive. Paperback: Cheaper, lighter, and more portable than hardcovers. E-books: Digital books available for e-readers like Kindle or software like Apple Books, Kindle, and Google Play Books.
3. How do I choose a Juki Lk 1850 Parts Manual User Guide book to read? Genres: Consider the genre you enjoy (fiction, non-fiction, mystery, sci-fi, etc.). Recommendations: Ask friends, join book clubs, or explore online reviews and recommendations. Author: If you like a particular author, you might enjoy more of their work.
4. How do I take care of Juki Lk 1850 Parts Manual User Guide books? Storage: Keep them away from direct sunlight and in a dry environment. Handling: Avoid folding pages, use bookmarks, and handle them with clean hands. Cleaning: Gently dust the covers and pages occasionally.
5. Can I borrow books without buying them? Public Libraries: Local libraries offer a wide range of books for borrowing. Book Swaps: Community book exchanges or online platforms where people exchange books.
6. How can I track my reading progress or manage my book collection? Book Tracking Apps: Goodreads, LibraryThing,

and Book Catalogue are popular apps for tracking your reading progress and managing book collections. Spreadsheets: You can create your own spreadsheet to track books read, ratings, and other details.

7. What are Juki Lk 1850 Parts Manual User Guide audiobooks, and where can I find them? Audiobooks: Audio recordings of books, perfect for listening while commuting or multitasking. Platforms: Audible, LibriVox, and Google Play Books offer a wide selection of audiobooks.
8. How do I support authors or the book industry? Buy Books: Purchase books from authors or independent bookstores. Reviews: Leave reviews on platforms like Goodreads or Amazon. Promotion: Share your favorite books on social media or recommend them to friends.
9. Are there book clubs or reading communities I can join? Local Clubs: Check for local book clubs in libraries or community centers. Online Communities: Platforms like Goodreads have virtual book clubs and discussion groups.
10. Can I read Juki Lk 1850 Parts Manual User Guide books for free? Public Domain Books: Many classic books are available for free as they're in the public domain. Free E-books: Some websites offer free e-books legally, like Project Gutenberg or Open Library.

### **Find Juki Lk 1850 Parts Manual User Guide :**

*math practice test for 9th grade eoct*

[math makes sense 6 workbook lesson 9](#)

[math papers 5 grade](#)

[mathematical literacy p1 dbc november 2014 memo](#)

[math olympiad division e problems and solutions](#)

[math 605 hw 3 solutions follandaca aca real analysis chapter 2](#)

[math 4h edexcel may 2005 mark scheme](#)

**math pmemo 2015 dbc june**

*math 7 8 skills practice circumference*

[math olympiad contest problems volume 2](#)

**math suggestion j s c 2014**

**math pacing guide for first grade**

[math paper grade2014](#)

**math kangaroo 2006 grade 2 answers**



math 2memorandum paper june

**Juki Lk 1850 Parts Manual User Guide :**

*editions of milkweed by jerry spinelli goodreads* - Jun 02 2022

web sep 9 2003 milkweed hardcover by jerry spinelli hardcover published january 1st 2004 by scholastic 1st first edition hardcover 208 pages more details want to read rate this book 1 of 5 stars 2 of 5 stars 3 of 5 stars 4 of 5 stars 5 of 5 stars

**milkweed novel wikipedia** - Aug 16 2023

web milkweed is a 2003 young adult historical fiction novel by american author jerry spinelli the book is about a boy in warsaw poland in the years of world war ii during the holocaust over time he is taken in by a jewish group of orphans and he must avoid the nazis or jackboots while living on the streets with other orphans

milkweed imdb - Feb 27 2022

web milkweed directed by mike owens wendie price owens jerry spinelli stargirl maniac magee loser takes us into the devastating setting of nazi occupied warsaw and tells a tale of hope

**milkweed literature guide teachervision** - Jan 09 2023

web jan 23 2020 in milkweed author jerry spinelli paints a vivid picture of the streets of the nazi occupied warsaw during world war ii as seen through the eyes of a young orphan this teacher s guide which includes summary discussion questions and activities will help in your instruction of the novel

**milkweed by jerry spinelli plot summary litcharts** - Feb 10 2023

web one day janina finds a milkweed plant thriving in an alley its fluffy seeds delight her making her think of angels meanwhile on a smuggling run to the nazi hotel misha runs into uri who hasn t been spending much time with the other orphans lately

**milkweed by jerry spinelli goodreads** - Jul 03 2022

web sep 9 2003 milkweed is an amazing book written by jerry spinelli that takes you on an amazing journey of a young boy s life during world war ii the holocaust i would really recommend this book to anyone to read this book you don t have to

*milkweed by jerry spinelli 9780375861475* - Apr 12 2023

web library media connection starred part survival adventure part holocaust history this novel tells the story through the eyes of a polish orphan on the run from the nazis starred review this is a superb addition to the canon of young adult literature

milkweed hardcover by jerry spinelli amazon com - Mar 31 2022

web jan 1 2003 milkweed hardcover by jerry spinelli hardcover january 1 2003 newbery medalist jerry spinelli takes us to

one of the most devastating settings imaginable nazi occupied warsaw and tells a tale of heartbreak hope and survival through the bright eyes of a young orphan

**milkweed jerry spinelli free download borrow and streaming** - Oct 06 2022

web milkweed by jerry spinelli publication date 2003 publisher random house children s books collection printdisabled internetarchivebooks contributor internet archive language english access restricted item true addeddate 2012 02 10 19 38 17 boxid ia177701 camera canon eos 5d mark ii city new york donor

**milkweed chapter 10 summary analysis litcharts** - Dec 28 2021

web need help with chapter 10 in jerry spinelli s milkweed check out our revolutionary side by side summary and analysis *milkweed spinelli jerry 1940 free download borrow and* - May 13 2023

web english 269 pages 21 cm this is the true story of jews and gypsies in warsaw during the nazi occupation but it is also the story of a street orphan who survives on quick thinking schemes to find food who believes in bread mothers and angels a tragic but beautiful account through the eyes of the innocent about the holocaust

[milkweed by jerry spinelli audiobooks on google play](#) - Sep 05 2022

web newbery medalist jerry spinelli takes us to one of the most devastating settings imaginable nazi occupied warsaw during world war ii and tells a tale of heartbreak hope and survival through the bright eyes of a young holocaust orphan

[amazon com milkweed ebook spinelli jerry kindle store](#) - Aug 04 2022

web sep 9 2003 newbery medal winning author jerry spinelli maniac mcgee stargirl paints a vivid picture of the streets of the nazi occupied warsaw during world war ii as seen through the eyes of a curious kind heartbreakingly naïve orphan with many names his name is stopthief when people shout stop thief as he flees with stolen bread or it s

**milkweed random house reader s circle amazon com** - Mar 11 2023

web mar 23 2010 newbery medalist jerry spinelli takes us to one of the most devastating settings imaginable nazi occupied warsaw during world war ii and tells a tale of heartbreak hope and survival through the bright eyes of a young holocaust orphan

**reading guide from milkweed penguin random house canada** - Nov 07 2022

web milkweed by jerry spinelli with the robust sales of holocaust and world war ii fiction like markus zusak s the book thief john boyne s the boy in the striped pajamas and milkweed s own laurel leaf edition see comparative titles the market seems ripe for this new trade paperback

[milkweed summary and study guide supersummary](#) - Jul 15 2023

web milkweed is a young adult historical fiction novel by jerry spinelli published in 2003 milkweed won the 2004 golden kite award and 2003 carolyn w field award in fiction the novel follows a young unnamed boy s life in warsaw poland during the

holocaust

*milkweed by jerry spinelli publishers weekly* - May 01 2022

web milkweed jerry spinelli knopf 15 95 224pp isbn 978 0 375 81374 0 for this wwii tale set in warsaw spinelli wringer invents a narrator akin to roberto benigni s character in

**milkweed book summary and activities jerry spinelli storyboard that** - Jan 29 2022

web milkweed by jerry spinelli is an award winning historical fiction novel written in 2003 the story is about a young boy fighting to survive the warsaw ghetto during world war ii the reader sees the brutality of the nazis and the inhumane treatment of the jewish people through misha s innocent eyes

**milkweed study guide literature guide litcharts** - Jun 14 2023

web a concise biography of jerry spinelli plus historical and literary context for milkweed milkweed plot summary a quick reference summary milkweed on a single page

[milkweed themes supersummary](#) - Dec 08 2022

web thanks for exploring this supersummary study guide of milkweed by jerry spinelli a modern alternative to sparknotes and cliffsnotes supersummary offers high quality study guides that feature detailed chapter summaries and analysis of major themes characters quotes and essay topics

*weird maths at the edge of infinity and beyond google books* - Oct 04 2023

web feb 1 2018 in this delightful journey of discovery david darling and extraordinary child prodigy agnijo banerjee draw connections between the cutting edge of modern maths

**weird maths at the edge of infinity and beyond amazon in** - Jun 19 2022

web weird maths is a lively accessible fun book about mathematics the maths that is all around us that defines us our intelligence our curiosity in this delightful journey of

**weird maths at the edge of infinity and beyond kindle edition** - Apr 17 2022

web feb 1 2018 weird maths at the edge of infinity and beyond kindle edition by darling david banerjee agnijo download it once and read it on your kindle device pc phones

**weird maths at the edge of infinity and beyond anna s archive** - Nov 24 2022

web is anything truly random does infinity actually exist could we ever see into other dimensions in this delightful journey of discovery david darling and extraordinary child

**weird maths at the edge of infinity and beyond amazon** - Aug 02 2023

web jun 22 2018 weird maths is a lively accessible fun book about mathematics the maths that is all around us that defines us our intelligence our curiosity in this delightful

**weird maths at the edge of infinity and beyond google books** - Mar 29 2023

web in this delightful journey of discovery david darling and extraordinary child prodigy agnijo banerjee draw connections between the cutting edge of modern maths and life as we

[weird maths at the edge of infinity and beyond paperback](#) - Aug 22 2022

web details sold by trans infopreneur inc see this image follow the author david darling weird maths at the edge of infinity and beyond paperback 20 june 2018 by d

**weird maths at the edge of infinity and beyond paperback** - Jul 21 2022

web amazon in buy weird maths at the edge of infinity and beyond book online at best prices in india on amazon in read weird maths at the edge of infinity and beyond

**weird maths at the edge of infinity and beyond** - Sep 22 2022

web in this delightful journey of discovery david darling and extraordinary child prodigy agnijo banerjee draw connections between the cutting edge of modern maths and life as we

**weird maths at the edge of infinity and beyond google books** - Jul 01 2023

web jul 4 2019 buy weird maths at the edge of infinity and beyond by darling david banerjee agnijo isbn 9781786074850 from amazon s book store everyday low

**weird maths at the edge of infinity and beyond** - Apr 29 2023

web weird maths at the edge of infinity and beyond ebook written by david darling agnijo banerjee read this book using google play books app on your pc android ios

*weird maths at the edge of infinity and beyond* - May 31 2023

web in this delightful journey of discovery david darling and extraordinary child prodigy agnijo banerjee draw connections between the cutting edge of modern maths and life as we

**weird maths at the edge of infinity and beyond** - Sep 03 2023

web weird maths at the edge of infinity and beyond darling david banerjee agnijo amazon sg books

**weird maths at the edge of infinity and beyond amazon com** - Feb 13 2022

*weird maths at the edge of infinity and beyond google play* - Feb 25 2023

web in this delightful journey of discovery david darling and extraordinary child prodigy agnijo banerjee draw connections between the cutting edge of modern maths and life as we

**weird maths at the edge of infinity and beyond paperback jan** - Mar 17 2022

**weird maths at the edge of infinity and beyond kindle** - Jan 27 2023

web english en epub 3 4mb weird maths 9781786072641 epub weird maths at the edge of infinity and beyond

**weird maths at the edge of infinity and beyond** - Dec 26 2022

web in this delightful journey of discovery david darling and extraordinary child prodigy agnijo banerjee draw connections between the cutting edge of modern maths and life as we

weird maths at the edge of infinity and beyond paperback - May 19 2022

web weird maths at the edge of infinity and beyond paperback jan 01 2018 ddarlingandabanerjee d darling amazon com au books

weird maths at the edge of infinity and beyond kindle edition - Oct 24 2022

web weird maths is a lively accessible fun book about mathematics the maths that is all around us that defines us our intelligence our curiosity in this delightful journey of

*advanced accountancy p i solapur university copy uniport edu* - Jan 27 2022

web mar 26 2023 advanced accountancy p i solapur university 3 14 downloaded from uniport edu ng on march 26 2023 by guest aspirants to make them familiar with the type

question paper advanced accountancy paper i m com - May 11 2023

web advanced accountancy paper i paper exam course m com department organization solapur university position exam date march 2018 city state

**advanced accountancy p i solapur university pdf uniport edu** - Mar 29 2022

web advanced accountancy p i solapur university 2 9 downloaded from uniport edu ng on july 11 2023 by guest im3f 2020 conference held in malaysia this collection of articles

**solapur university admission 2023 courses fees** - Apr 10 2023

web apr 1 2014 new delhi the results of the national aptitude test in architecture nata 2023 phase 3 will be released on july 18 2023 aspirants will be able to check their

**solapur university ph d admissions eligibility** - Dec 06 2022

web nov 24 2020 punyashlok ahilyadevi holkar solapur university solapur maharashtra has 84 courses top courses at punyashlok ahilyadevi holkar solapur university

advanced accountancy p i solapur university copy uniport edu - Oct 24 2021

web may 22 2023 advanced accountancy p i solapur university 2 10 downloaded from uniport edu ng on may 22 2023 by guest to producers and processors this work

**advanced accountancy p i solapur university pdf uniport edu** - Apr 29 2022

web jun 12 2023 this online statement advanced accountancy p i solapur university can be one of the options to accompany you in the same way as having other time it will not

**advanced accountancy p i solapur university pdf uniport edu** - Jan 07 2023

web jun 11 2023 advanced accountancy p i solapur university 1 6 downloaded from uniport edu ng on june 11 2023 by guest advanced accountancy p i solapur

*advanced accountancy p i solapur university pdf uniport edu* - Jul 01 2022

web jul 28 2023 knowledge of number theory and advanced math or present mainly theoretical ideas forouzan presents difficult security topics from the ground up a gentle

advanced accountancy p i solapur university pdf uniport edu - Aug 14 2023

web jul 13 2023 advanced accountancy p i solapur university is available in our digital library an online access to it is set as public so you can get it instantly our digital library

*advanced accountancy p i solapur university pdf uniport edu* - Nov 05 2022

web mar 21 2023 advanced accountancy p i solapur university 1 9 downloaded from uniport edu ng on march 21 2023 by guest advanced accountancy p i solapur

**solapur university solapur semester pattern syllabus** - Jun 12 2023

web advanced accounting p c tulsian tata mcgraw solapur university solapur b com iii sem v auditing advanced accountancy optional paper ii w e f june

**advanced accountancy p i solapur university pdf uniport edu** - May 31 2022

web aug 2 2023 advanced accountancy p i solapur university 1 9 downloaded from uniport edu ng on august 2 2023 by guest advanced accountancy p i solapur

**question paper advanced accountancy paper i m com** - Feb 08 2023

web question paper advanced accountancy paper i m com solapur university university maharashtra solapur

**advanced accountancy p i solapur university pdf pdf** - Sep 03 2022

web title advanced accountancy p i solapur university pdf pdf snapshot segmetrics io created date 8 31 2023 4 31 14 pm

**advanced accountancy p i solapur university copy uniport edu** - Nov 24 2021

web advanced accountancy p i solapur university 1 11 downloaded from uniport edu ng on july 21 2023 by guest advanced accountancy p i solapur university this is likewise

*solapur university solapur university of solapur* - Jul 13 2023

web advanced accountancy jain narang cost accounting methods and practice b k bhar cost accounting jain and narang cost accounting p v ratnam cost

[university of solapur wikipedia](#) - Mar 09 2023

web punyashlok ahilyadevi holkar solapur university was established on 1 august 2004 and was inaugurated on 3 august 2004 by the governor of maharashtra the formation of the

[advanced accountancy p i solapur university pdf uniport edu](#) - Aug 02 2022

web jul 28 2023 begin getting this info get the advanced accountancy p i solapur university link that we give here and check out the link you could purchase guide

**advanced accountancy p i solapur university uniport edu** - Feb 25 2022

web jul 27 2023 make bargains to download and install advanced accountancy p i solapur university in view of that simple elementary first aid international maritime

[advanced accountancy p i solapur university pdf uniport edu](#) - Oct 04 2022

web may 15 2023 you could buy guide advanced accountancy p i solapur university or get it as soon as feasible you could quickly download this advanced accountancy p i

[advanced accountancy p i solapur university pdf uniport edu](#) - Dec 26 2021

web jun 4 2023 start getting this info acquire the advanced accountancy p i solapur university associate that we provide here and check out the link you could buy guide