

# Información Técnica para Taller

***VOLVO***

***D13***

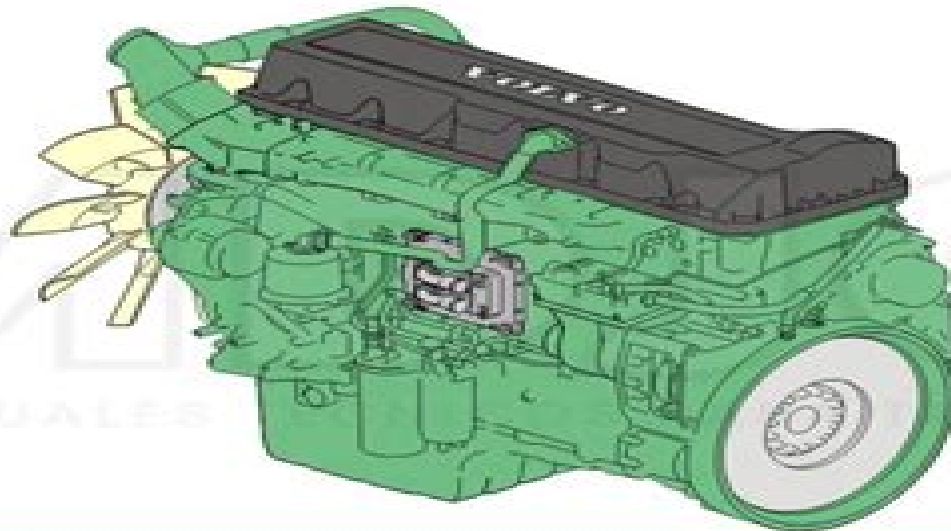

**Generalidades / Especificaciones / Lubricación  
Combustible / Regulación / Códigos de Fallas  
Admisión y Escape / Pares de Apriete / Ajustes / Etc.**



# Manual Motor Volvo D13

**L Manion**



## **Manual Motor Volvo D13:**

*Moody's International Manual* ,2000      **Mergent International Manual** ,2009      Federal Register ,1989-11-22

**Moody's Industrial Manual** ,1989 Covering New York American regional stock exchanges international companies

**The Commercial Motor** ,1979-05      **TOTAL QUALITY MANAGEMENT, SECOND EDITION** MUKHERJEE, P.

N.,2024-08-01 This book in its second edition presents a comprehensive view of concepts principles and practices of Total Quality Management TQM from basics through advanced tools and techniques for practical implementation It is well known that Total Organization Involvement in understanding and implementing TQM along with the integrated business strategy provided Japanese organizations with a strong platform for a meteoric rise to world class performance and global leadership in every sphere of their operation The success of TQM therefore depends a lot on the strong foundation and infrastructure of an organization This is the crux of the author s theory of Holistic Management System for World class Performance and Leadership expounded in this book It is a TQM based model that helps create a world class management system for performance excellence and global leadership The second edition of the book introduces three new chapters on Quality 4 0 Service Quality and Contemporary and Emerging Concepts of TQM to keep the readers abreast of the latest advancements in the field The last chapter covers Quality 5 0 Society 5 0 AI ML Deep Learning Robotics Cobots and Chatbots These technologies are integrated to synchronize TQM with latest trends in industry and society to give hands on experience to the students and professionals Besides the chapter on Six Sigma has been revised and updated The concluding part of the book cites several examples of practical implementation of TQM principles and practices in various manufacturing and service sectors of the Indian industry providing elaboration and analysis of each case study The book is aimed at undergraduate and postgraduate students of management as well as students of most engineering disciplines It can also be used by the industries as a valuable guide to continuous improvement and implementation of a world class management system in line with the TQM principles and practices In a nutshell the book provides wide coverage of areas related to TQM and integrates all its processes tools and techniques under one management system to help businesses grow and excel This is indeed the unique feature of the book The first edition of the book is already among the top 20 all time best book on Total Quality Management and has 88 citations globally TARGET AUDIENCE PGP Production Operations Management MBA Production Operations Management PGDM Operations Management      *Power Farming in Australia and New Zealand Technical Manual* ,1984      **Motor Truck News** ,1960      **ISATA 81** ,1981      **Automotive Supplier 99** Rapra Technology,1999

Proceedings ,1981      **TOTAL QUALITY MANAGEMENT** P. N. MUKHERJEE,2006-10-30 This book presents a comprehensive view of concepts principles and practices of Total Quality Management TQM from basics through advanced tools and techniques for practical implementation It is well known that Total Organization Involvement in understanding and implementing TQM along with the integrated business strategy provided Japanese organizations with a strong platform for a

meteoric rise to world class performance and global leadership in every sphere of their operation The success of TQM therefore depends a lot on the strong foundation and infrastructure of an organization This is the crux of the author s theory of Holistic Management System for World class Performance and Leadership expounded in this book It is a TQM based model that helps create a world class management system for performance excellence and global leadership The concluding part of the book cites several examples of practical implementation of TQM principles and practices in various manufacturing and service sectors of the Indian industry providing elaboration and analysis of each case study The book is aimed at undergraduate and postgraduate students of management as well as students of most engineering disciplines It can also be used by the industries as a valuable guide to continuous improvement and implementation of a world class management system in line with the TQM principles and practices In a nutshell the book provides wide coverage of areas related to TQM and integrates all its processes tools and techniques under one management system to help businesses grow and excel This is indeed the unique feature of the book

**Adventures from the Technology Underground** William Gurstelle,2009-02-04  
The technology underground is a thriving humming and often literally scintillating subculture of amateur inventors and scientific envelope pushers who dream up design and build machines that whoosh rumble fly and occasionally hurl pumpkins across enormous distances In the process they astonish us with what is possible when human imagination and ingenuity meet nature s forces and materials William Gurstelle spent two years exploring the most fascinating outposts of this world of wonders meeting and talking to the men and women who care far more for the laws of physics than they do for mundane matters like government regulations and their own personal safety Adventures from the Technology Underground is Gurstelle s lively and weirdly compelling report of his travels In these pages we meet Frank Kosdon and others who draw the scrutiny of the FAA ATF and other federal agencies in their pursuit of high power amateur rocketry which they demonstrate to impressive and sometimes explosive effect at the annual LDRS gathering held in various remote and unpopulated areas a necessary consideration since that acronym stands for Large Dangerous Rocket Ships Here also are the underground technologists who turn up at the Burning Man festival in the Nevada high desert including Lucy Hosking the engineer from Hell and the creator of Satan s Calliope aka the World s Loudest Thing a pipe organ made from jet engines Also at Burning Man is Austin Dr MegaVolt Richard who braves the arcing sputtering six digit voltages of a giant Tesla coil in his protective metal suit Add in a trip to see medieval style catapults air cannons and supersized slingshots in action at the World Championship Punkin Chunkin competition in Sussex County Delaware and forays to the postapocalyptic enclaves of the flamethrower builders and the future noir pits of the fighting robots and you have proof positive that the age of invention is still going strong In the world of science and engineering despite its buttoned down image there s plenty of fun humor and sheer wonder to be found at the fringes Adventures from the Technology Underground takes you there Launch homemade high power rockets Catapult pumpkins the better part of a mile Watch robot gladiators saw flip and pound one another into

high tech junk heaps Dazzle the eye with electrical discharges measured in the hundreds of thousands of volts Play with flamethrowers potato guns and other decidedly unsafe toys If this is your idea of fun you ll have a major good time on this wild ride through today s Technology Underground From the Burning Man festival in Nevada s high desert to the latest gathering of Large Dangerous Rocket Ship builders to Delaware s annual Punkin Chunkin competition a celebration of science radical self expression and beer you ll meet the inspired government unregulated and corporately unfettered men and women who operate at the furthest fringes of science engineering and wild eyed arc welding building the catapults ultra high voltage electrical devices incendiary artworks fighting robots and other machines that demonstrate what s possible when physics meets human ingenuity

**Fleet Owner** ,1991      **Automobile Fuel Tanks** Lois Flynn,1979      World  
Wastes ,1994      **Solid Wastes Management/Refuse Removal Journal** ,1982      **Motor Business Europe** ,1997  
**Volvo Down Under** Pedr Davis,Tony Davis,1990      **The Wall Street Journal** ,1989

## **Manual Motor Volvo D13** Book Review: Unveiling the Magic of Language

In an electronic digital era where connections and knowledge reign supreme, the enchanting power of language has become more apparent than ever. Its capability to stir emotions, provoke thought, and instigate transformation is really remarkable. This extraordinary book, aptly titled "**Manual Motor Volvo D13**," published by a highly acclaimed author, immerses readers in a captivating exploration of the significance of language and its profound impact on our existence. Throughout this critique, we will delve to the book's central themes, evaluate its unique writing style, and assess its overall influence on its readership.

[https://splashdogs.com/book/detail/default.aspx/ipod\\_4th\\_generation\\_screen\\_repair\\_kit.pdf](https://splashdogs.com/book/detail/default.aspx/ipod_4th_generation_screen_repair_kit.pdf)

### **Table of Contents Manual Motor Volvo D13**

1. Understanding the eBook Manual Motor Volvo D13
  - The Rise of Digital Reading Manual Motor Volvo D13
  - Advantages of eBooks Over Traditional Books
2. Identifying Manual Motor Volvo D13
  - Exploring Different Genres
  - Considering Fiction vs. Non-Fiction
  - Determining Your Reading Goals
3. Choosing the Right eBook Platform
  - Popular eBook Platforms
  - Features to Look for in an Manual Motor Volvo D13
  - User-Friendly Interface
4. Exploring eBook Recommendations from Manual Motor Volvo D13
  - Personalized Recommendations
  - Manual Motor Volvo D13 User Reviews and Ratings
  - Manual Motor Volvo D13 and Bestseller Lists
5. Accessing Manual Motor Volvo D13 Free and Paid eBooks

- Manual Motor Volvo D13 Public Domain eBooks
  - Manual Motor Volvo D13 eBook Subscription Services
  - Manual Motor Volvo D13 Budget-Friendly Options
6. Navigating Manual Motor Volvo D13 eBook Formats
- ePub, PDF, MOBI, and More
  - Manual Motor Volvo D13 Compatibility with Devices
  - Manual Motor Volvo D13 Enhanced eBook Features
7. Enhancing Your Reading Experience
- Adjustable Fonts and Text Sizes of Manual Motor Volvo D13
  - Highlighting and Note-Taking Manual Motor Volvo D13
  - Interactive Elements Manual Motor Volvo D13
8. Staying Engaged with Manual Motor Volvo D13
- Joining Online Reading Communities
  - Participating in Virtual Book Clubs
  - Following Authors and Publishers Manual Motor Volvo D13
9. Balancing eBooks and Physical Books Manual Motor Volvo D13
- Benefits of a Digital Library
  - Creating a Diverse Reading Collection Manual Motor Volvo D13
10. Overcoming Reading Challenges
- Dealing with Digital Eye Strain
  - Minimizing Distractions
  - Managing Screen Time
11. Cultivating a Reading Routine Manual Motor Volvo D13
- Setting Reading Goals Manual Motor Volvo D13
  - Carving Out Dedicated Reading Time
12. Sourcing Reliable Information of Manual Motor Volvo D13
- Fact-Checking eBook Content of Manual Motor Volvo D13
  - Distinguishing Credible Sources
13. Promoting Lifelong Learning
- Utilizing eBooks for Skill Development

- Exploring Educational eBooks
14. Embracing eBook Trends
- Integration of Multimedia Elements
  - Interactive and Gamified eBooks

### **Manual Motor Volvo D13 Introduction**

In this digital age, the convenience of accessing information at our fingertips has become a necessity. Whether its research papers, eBooks, or user manuals, PDF files have become the preferred format for sharing and reading documents. However, the cost associated with purchasing PDF files can sometimes be a barrier for many individuals and organizations. Thankfully, there are numerous websites and platforms that allow users to download free PDF files legally. In this article, we will explore some of the best platforms to download free PDFs. One of the most popular platforms to download free PDF files is Project Gutenberg. This online library offers over 60,000 free eBooks that are in the public domain. From classic literature to historical documents, Project Gutenberg provides a wide range of PDF files that can be downloaded and enjoyed on various devices. The website is user-friendly and allows users to search for specific titles or browse through different categories. Another reliable platform for downloading Manual Motor Volvo D13 free PDF files is Open Library. With its vast collection of over 1 million eBooks, Open Library has something for every reader. The website offers a seamless experience by providing options to borrow or download PDF files. Users simply need to create a free account to access this treasure trove of knowledge. Open Library also allows users to contribute by uploading and sharing their own PDF files, making it a collaborative platform for book enthusiasts. For those interested in academic resources, there are websites dedicated to providing free PDFs of research papers and scientific articles. One such website is Academia.edu, which allows researchers and scholars to share their work with a global audience. Users can download PDF files of research papers, theses, and dissertations covering a wide range of subjects. Academia.edu also provides a platform for discussions and networking within the academic community. When it comes to downloading Manual Motor Volvo D13 free PDF files of magazines, brochures, and catalogs, Issuu is a popular choice. This digital publishing platform hosts a vast collection of publications from around the world. Users can search for specific titles or explore various categories and genres. Issuu offers a seamless reading experience with its user-friendly interface and allows users to download PDF files for offline reading. Apart from dedicated platforms, search engines also play a crucial role in finding free PDF files. Google, for instance, has an advanced search feature that allows users to filter results by file type. By specifying the file type as "PDF," users can find websites that offer free PDF downloads on a specific topic. While downloading Manual Motor Volvo D13 free PDF files is convenient, its important to note that copyright laws must be respected. Always ensure that the PDF files you download are legally available



for free. Many authors and publishers voluntarily provide free PDF versions of their work, but it's essential to be cautious and verify the authenticity of the source before downloading Manual Motor Volvo D13. In conclusion, the internet offers numerous platforms and websites that allow users to download free PDF files legally. Whether it's classic literature, research papers, or magazines, there is something for everyone. The platforms mentioned in this article, such as Project Gutenberg, Open Library, Academia.edu, and Issuu, provide access to a vast collection of PDF files. However, users should always be cautious and verify the legality of the source before downloading Manual Motor Volvo D13 any PDF files. With these platforms, the world of PDF downloads is just a click away.

### FAQs About Manual Motor Volvo D13 Books

1. Where can I buy Manual Motor Volvo D13 books? Bookstores: Physical bookstores like Barnes & Noble, Waterstones, and independent local stores. Online Retailers: Amazon, Book Depository, and various online bookstores offer a wide range of books in physical and digital formats.
2. What are the different book formats available? Hardcover: Sturdy and durable, usually more expensive. Paperback: Cheaper, lighter, and more portable than hardcovers. E-books: Digital books available for e-readers like Kindle or software like Apple Books, Kindle, and Google Play Books.
3. How do I choose a Manual Motor Volvo D13 book to read? Genres: Consider the genre you enjoy (fiction, non-fiction, mystery, sci-fi, etc.). Recommendations: Ask friends, join book clubs, or explore online reviews and recommendations. Author: If you like a particular author, you might enjoy more of their work.
4. How do I take care of Manual Motor Volvo D13 books? Storage: Keep them away from direct sunlight and in a dry environment. Handling: Avoid folding pages, use bookmarks, and handle them with clean hands. Cleaning: Gently dust the covers and pages occasionally.
5. Can I borrow books without buying them? Public Libraries: Local libraries offer a wide range of books for borrowing. Book Swaps: Community book exchanges or online platforms where people exchange books.
6. How can I track my reading progress or manage my book collection? Book Tracking Apps: Goodreads, LibraryThing, and Book Catalogue are popular apps for tracking your reading progress and managing book collections. Spreadsheets: You can create your own spreadsheet to track books read, ratings, and other details.
7. What are Manual Motor Volvo D13 audiobooks, and where can I find them? Audiobooks: Audio recordings of books, perfect for listening while commuting or multitasking. Platforms: Audible, LibriVox, and Google Play Books offer a wide

selection of audiobooks.

8. How do I support authors or the book industry? Buy Books: Purchase books from authors or independent bookstores. Reviews: Leave reviews on platforms like Goodreads or Amazon. Promotion: Share your favorite books on social media or recommend them to friends.
9. Are there book clubs or reading communities I can join? Local Clubs: Check for local book clubs in libraries or community centers. Online Communities: Platforms like Goodreads have virtual book clubs and discussion groups.
10. Can I read Manual Motor Volvo D13 books for free? Public Domain Books: Many classic books are available for free as they're in the public domain. Free E-books: Some websites offer free e-books legally, like Project Gutenberg or Open Library.

### **Find Manual Motor Volvo D13 :**

[\*ipod 4th generation screen repair kit\*](#)

[\*ipod touch 4th generation screen repair cost\*](#)

[\*ios 5 essentials daniel steven f\*](#)

[\*irak les armeacutes du chaos seconde eacutedition\*](#)

[\*iphone app vehicle log book\*](#)

[\*iowa servsafe alcohol study guide\*](#)

**iq works manual**

**ios 7 user guide**

[\*invincible t16 histoires robert kirkman\*](#)

**ir322printer user guide**

[\*iphone 3g 16gb manual\*](#)

[\*ipod touch quick start guide\*](#)

[\*iphone 4s screw diagram\*](#)

[\*ipod 30gb user manual\*](#)

[\*ipod nano hard reset\*](#)

### **Manual Motor Volvo D13 :**

B Engineering Economic Analysis 9th Edition, SOLUTION As an introductory text on engineering economic analysis, the book

concentrates on the principles that provide a solid foundation in the pursuit of more ... Engineering Economic Analysis 9th ED by Newnan Here are the solution manual to some titles.. ... SOLUTIONS MANUAL: A First Course in Probability Theory, 6th edition, by S. Ross. ... SOLUTIONS MANUAL: ... SOLUTION MANUAL for Engineering Economic Analysis ... SOLUTION MANUAL for Engineering Economic Analysis 9th Edition(Newnan, Eschenbach, Lavelle). Content type. User Generated. School. Saint Louis University. Course. Solution Manual - Engineering Economic Analysis 9th ... Solution Manual - Engineering Economic Analysis 9th Edition Ch02 · Annual inspection costs - Initial construction costs · Annual costs of permits - Legal costs ... ENGINEERING ECONOMIC ANALYSIS NINTH EDITION Instructor's Manual by the authors with complete solutions to all end-of-chapter problems. The compoundinterest tables from the textbook are available in ... Solution Manual - Engineering Economic Analysis 9th ... Solution Manual - Engineering Economic Analysis 9th Edition Ch09 Other Analysis Techniques. Course: Economics (ECON201). 321 Documents. Students shared 321 ... engineering economy 9th edition solution manual thuesen... Engineering Economy 9th Edition Solution Manual Thuesen Engineering Economic Analysis (11th Edition) PDF This item: Engineering Economy (9th Edition) See ... Solution Manual (Engineering Economic Analysis Product information. Publisher, Engineering Press; 4th edition (January 1, 1991). Language, English. Unknown Binding, 0 pages. ISBN-10, 0910554803. ISBN-13 ... Engineering Economic Analysis Solution Manual Get instant access to our step-by-step Engineering Economic Analysis solutions manual. Our solution manuals are written by Chegg experts so you can be ... Engineering Economic Analysis, Solutions Engineering economic analysis ... Engineering Economy Solution Manual 8th Edition. 380 Pages·2018·8.53 MB·New ... Digital Film and Television Production < University of Florida To graduate with this major, students must complete all university, college, and major requirements. Department Information. The Media Production, Management, ... Film and Media Studies - UF Catalog - University of Florida Courses. ANT 3390 Visual Anthropology 3 Credits. Grading Scheme: Letter Grade. Uses photography and film as tools and products of social science ... Media Production, Management, and Technology - UF Catalog The University of Florida's Media Production, Management, and Technology program is one of the most comprehensive in the country, offering specializations ... Film and Media Studies - Department of English Welcome · Undergraduate Studies · Graduate Studies · About Our Faculty · Courses · Filmmaking · UF · Stay Connected. Photography » Creative Services » The information will help ensure that your photo shoot will go smoothly. Our goal is to produce the best images that tell your stories in order to further the ... Production Guidelines UF Health Communications uses the project management system, Asana, to input and manage our workload. Print Production Timeline The purpose of the print ... Plan & Market Events - Filming & Photography in the MSC Filming in the Marshall Student Center may not interfere with building operations and requires prior approval. University Departments, Current Students, and ... College of Motion Picture Arts - Florida State University Rigorous, hands-on programs (BFA or MFA) that provide a story-first education and prepare students for a career in film with industry-standard skills. Filming location

matching "university of florida, gainesville ... Exclude · Steve Martin, Keanu Reeves, Martha Plimpton, Tom Hulce, Rick Moranis, Jason. 1. · Just Cause (1995). 2. · Run the Race (2018). 3. · The Naked Ape (1973) ... Are there any movies about UF? : r/ufl The Scream horror movie franchise is based off of the UF/Santa Fe murders in the 1990s. Even though they changed the story so it takes place ... T. Watson: Photographer of Lythe, near Whitby, est. 1892 T. Watson: Photographer of Lythe, near Whitby, est. 1892. 5.0 5.0 out of 5 stars 1 Reviews. T. Watson: Photographer of Lythe, near Whitby, est. 1892. T.Watson 1863-1957 Photographer of Lythe Near Whitby T.Watson 1863-1957 Photographer of Lythe Near Whitby. 0 ratings by Goodreads · Richardson, Geoffrey. Published by University of Hull Press, 1992. T.Watson 1863-1957 Photographer of Lythe, near Whitby. A well produced 146 pp. monograph on Thomas Watson.A professional photographer and contemporary of Frank Meadow Sutcliffe working in the same location. T.Watson 1863-1957 Photographer of Lythe Near Whitby T.Watson 1863-1957 Photographer of Lythe Near Whitby ... Only 1 left in stock. ... Buy from the UK's book specialist. Enjoy same or next day dispatch. A top-rated ... T.Watson 1863-1957 Photographer of Lythe Near Whitby T.Watson 1863-1957 Photographer of Lythe Near Whitby by Geoffrey Richardson (Paperback, 1992). Be the first to write a review. ... Accepted within 30 days. Buyer ... Nostalgic North Riding ... Watson, Lythe Photographer. Thomas Watson was born in Ruswarp in 1863 but was moved to Lythe, just east of Sandsend, a couple of years later. Nostalgic North Riding | In this short film, Killip presents a ... Thomas Watson was born in Ruswarp in 1863 but was moved to Lythe, just east of Sandsend, a couple of years later. He went to work at Mulgrave ... Thomas Watson's photographic studio, Lythe near Whitby, ... Mar 16, 2011 — Thomas Watson's photographic studio, Lythe near Whitby, in 2008. Look at the terrible state of the wooden sheds that once comprised the ... Souvenir of.SANDSEND and Neighbourhood. ... Souvenir of.SANDSEND and Neighbourhood. Photographic Views of Sandsend Photographed and Published by T.Watson, Lythe. Watson, Thomas 1863-1957: Editorial: W & T ...